

## Identification and Overview

BAPI's Zone Pressure Multi-Sensor is the most flexible pressure sensor on the market. Output, range, units, directionality, and response time are quickly set in the field with no tools, no power and no small components.

The optional LCD display helps with troubleshooting because it displays the actual differential pressure over the entire operational range regardless of which pressure range is selected for output to the system controller. Three LEDs on the face of the unit indicate when the pressure is "Out of Range Low", "In Range" or "Out of Range High".

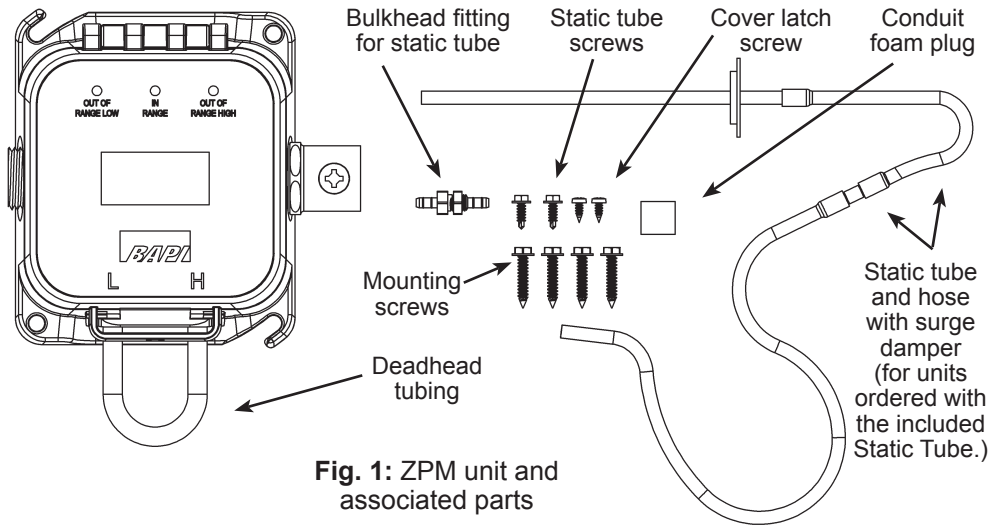

**Fig. 1:** ZPM unit and associated parts

## Switch Setup - Outputs, Ranges, Units/Response

Do not have power applied to unit when changing settings. After changing settings, apply power and Auto-Zero the unit in its orientation of operation.

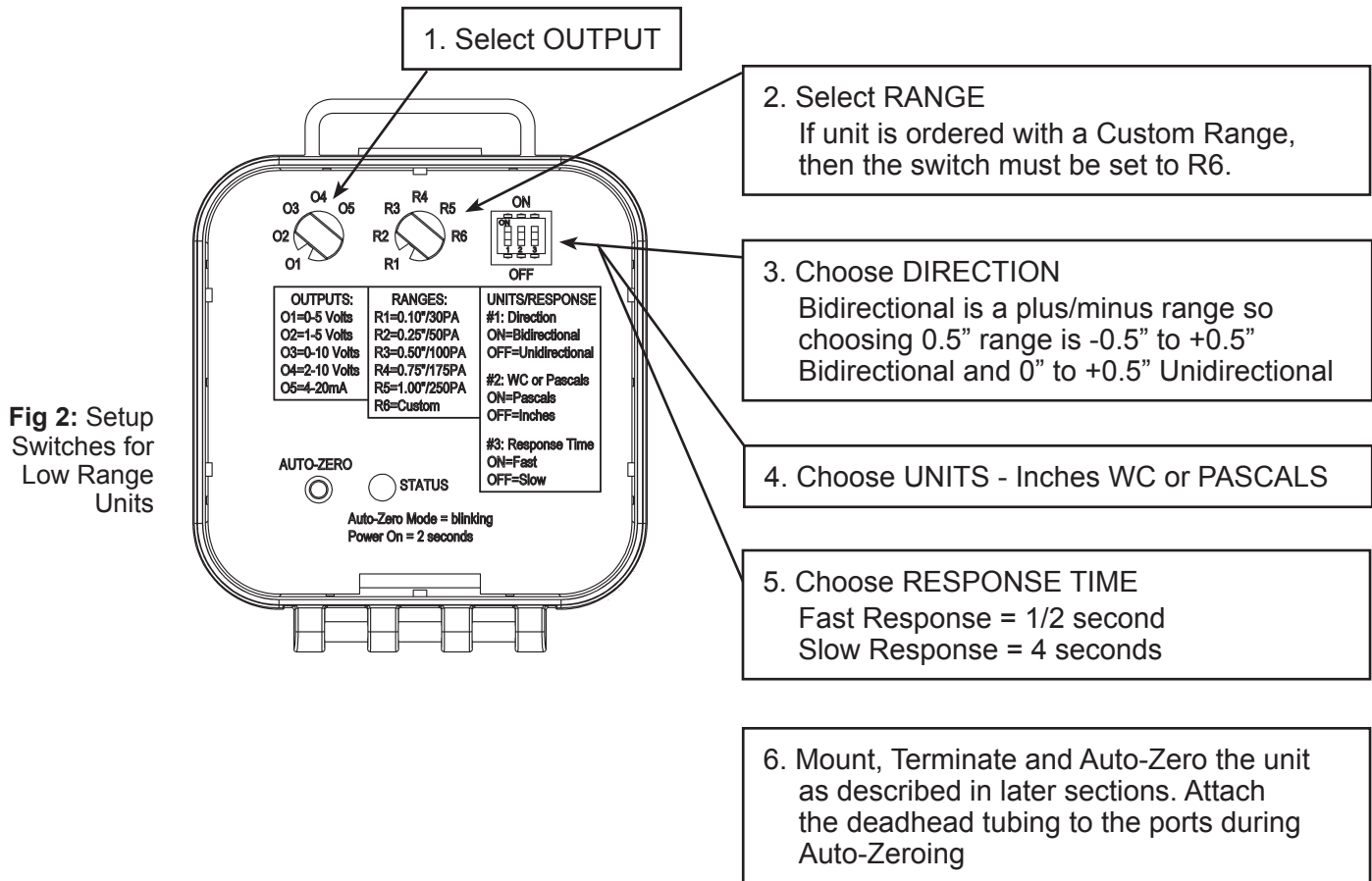

Specifications subject to change without notice.

## Mounting

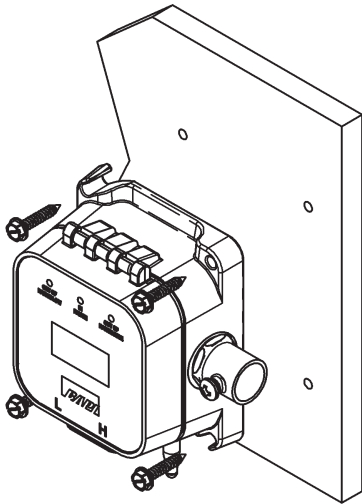

**Fig. 3:** ZPM Mounting  
(for units without Attached Tube option)

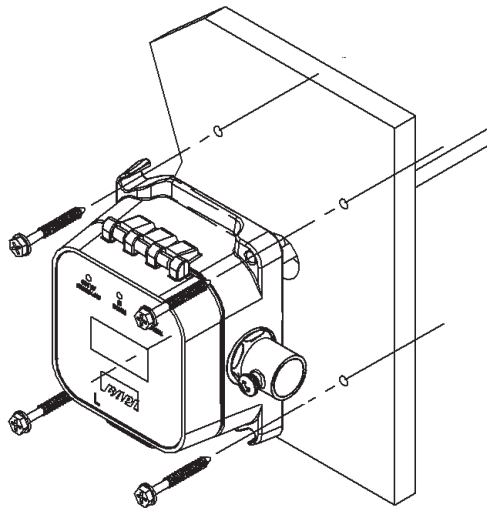

**Fig. 4:** ZPM Mounting  
(for units with Attached Tube option)

Attach the unit to its mounting surface with four self-tapping #10x3/4" sheet metal screws through the holes in the mounting feet. The preferred mounting orientation is with the pressure ports facing down.

Remove the deadhead tubing and push the system tubing onto the port nipple without creating any kinks or holes.

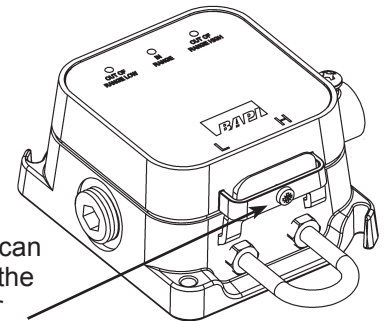

**Fig. 5:** Cover Latch Screw

A locking screw can be inserted into the hole in the cover latch to prevent unintentional cover openings.

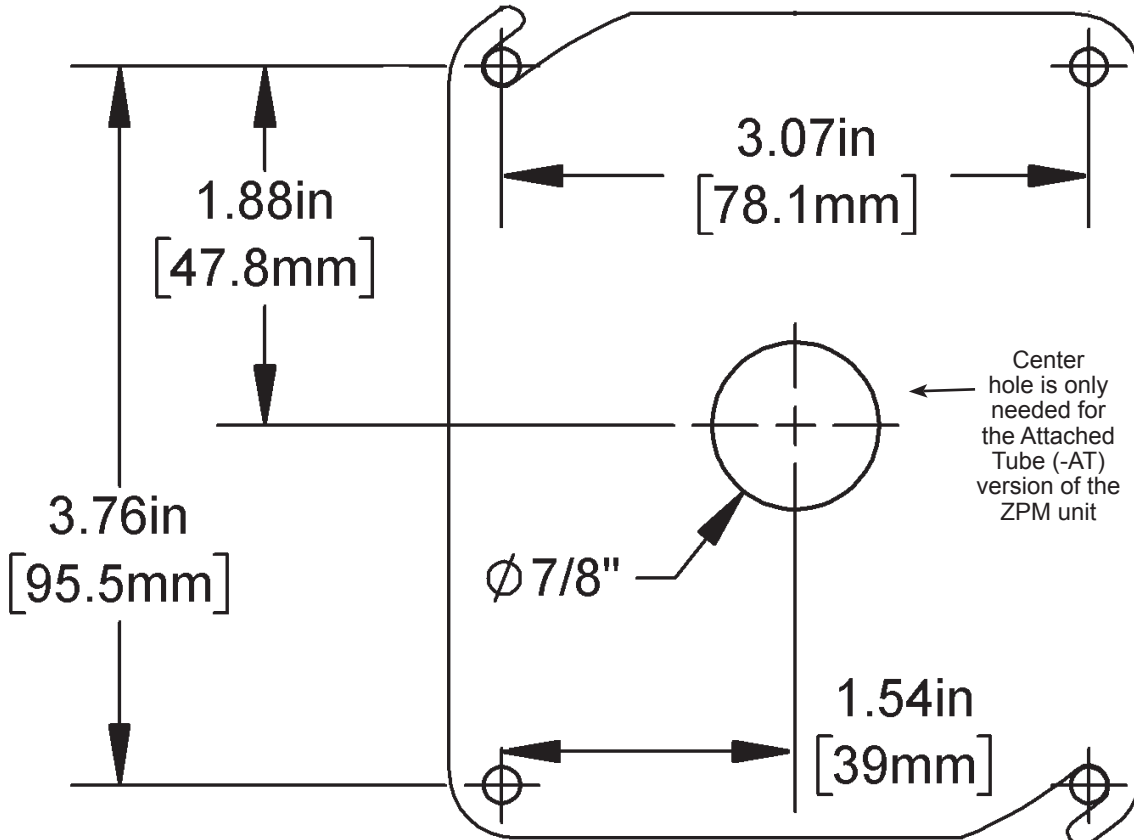

**Fig. 6:** Mounting Hole Template - shown actual size  
(BAPI recommends creating 5/32" pilot holes for the #10x3/4" self-tapping mounting screws.)

Specifications subject to change without notice.

### Output Termination



BAPI recommends wiring the product with power disconnected. Proper supply voltage, polarity and wiring connections are important to a successful installation. Not observing these recommendations may damage the product and void the warranty.

To ensure that all wires are properly terminated, twist the stripped ends of each wire together before inserting into the terminals. Gently tug on the wire after inserting into the terminal to verify a good connection.

**Table 1: ZPM Termination**

Output Signal	PWR Terminal	GND/4-20 Terminal	Vout Terminal
4 to 20 mA	7 to 40 VDC	4 to 20 mA Signal To Controller Analog Input	Not Used
0 to 5 or 1 to 5 VDC	7 to 40 VDC or 18 to 32 VAC	To Controller Ground	VDC Signal To Controller Analog Input
0 to 10 or 2 to 10 VDC	13 to 40 VDC or 18 to 32 VAC	To Controller Ground	VDC Signal To Controller Analog Input

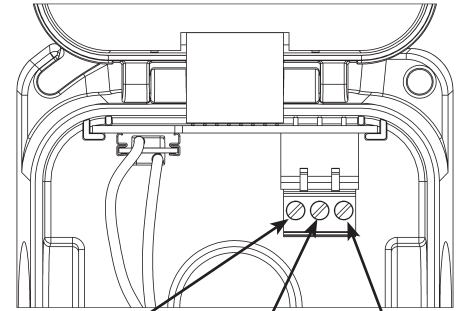

PWR Terminal    GND/4-20 Terminal    Vout Terminal

**Fig. 7: ZPM Wiring Terminals**

### Auto-Zero Operation

Auto-Zeroing must be done after the initial setup and after any changing of settings.

1. Make sure power is applied
2. Deadhead ports
4. Press the Auto-Zero button for 2 seconds (LED blinks)
5. Remove deadhead after LED stops blinking
6. Attach system tubing

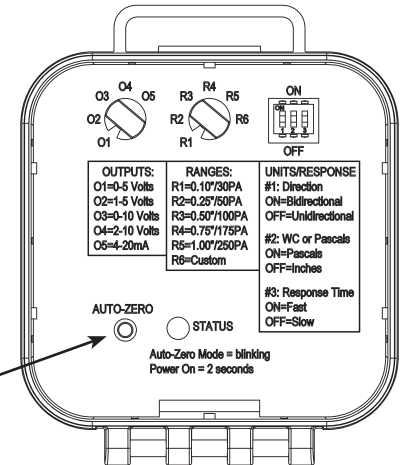

**Fig 6:**  
Auto-Zero Button

### Status LED Operation

**LED Off:** No power is applied or the unit is in 4 to 20 mA Mode

**LED On:** LED is on when power is applied and voltage output is selected. When 4 to 20 mA output is selected, the light is on for 2 seconds at power up then goes off.

**LED Blinking Fast:** Auto-Zero or Error Mode

**LED Blinking Slow:** The pressure measurement is above or below the selected pressure range. Note: When the reading is above or below the selected pressure range, the LCD on the face of the unit will alternate between showing the actual reading and showing "err".

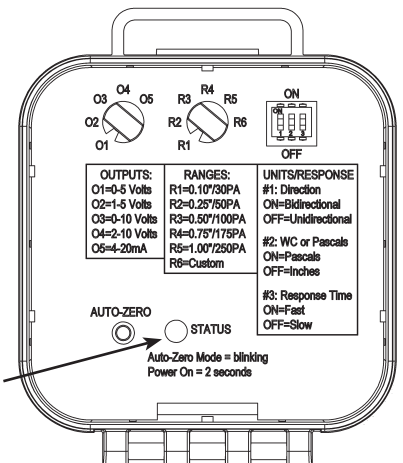

**Fig 7:**  
Status LED on the inside of the cover

Specifications subject to change without notice.

## Typical Applications

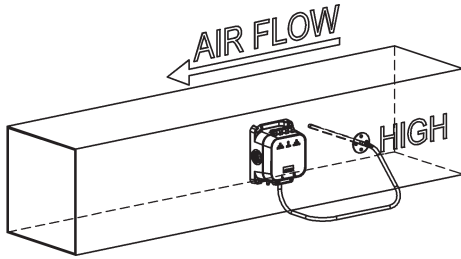

**Fig. 8:** Duct Static Pressure Monitoring (ZPM Pressure Sensor mounted on the duct with a Static Pressure Probe in the duct.)

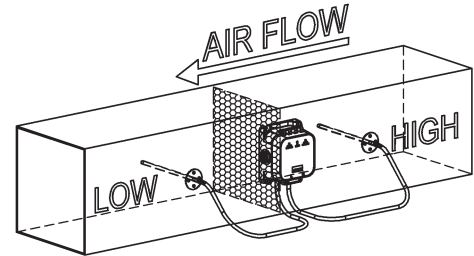

**Fig. 9:** Air Filter Pressure Drop Monitoring (ZPM Pressure Sensor mounted on the duct with a Static Pressure Probe on either side of the filter in a duct.)

**NOTE:** Best practice is to form a drip loop in the tubing to prevent condensation from reaching the ZPM.

## Troubleshooting

### POSSIBLE PROBLEMS:

LED does not light

LED is blinking fast  
(1/2 second on, 1/2 second off)

Display is alternating between a number and "err"

Output stuck (high or low)

Output not tracking pressure properly

### POSSIBLE SOLUTIONS:

- Check power connections for proper power

- The unit may be performing an auto-zero. Wait 10 seconds and check again.  
- Sensor is in an Error Mode. Cycle power.

- The measurement is out of selected range.

- Remove pressure from ports and perform auto-zero procedure

- Check rotary switch for proper pressure range selection  
- Check rotary switch for proper output range selection

## Specifications

### Power:

7 to 40 VDC  
for 4 to 20 mA Output

7 to 40 VDC or 18 to 32 VAC  
for 0 to 5 or 1 to 5 V Output

13 to 40 VDC or 18 to 32 VAC  
for 0 to 10 or 2 to 10 V Output

### Port Size:

1/4" tubing (1/8" to 3/16" I.D.)

### Selectable Low Ranges

Inches WC	Pascals
0 to 0.10.....	0 to 30
0 to 0.25.....	0 to 50
0 to 0.50.....	0 to 100
0 to 0.75.....	0 to 175
0 to 1.00.....	0 to 250
-0.10 to 0.10 .....	-30 to 30
-0.25 to 0.25 .....	-50 to 50
-0.50 to 0.50 .....	-100 to 100
-0.75 to 0.75 .....	-175 to 175
-1.00 to 1.00 .....	-250 to 250

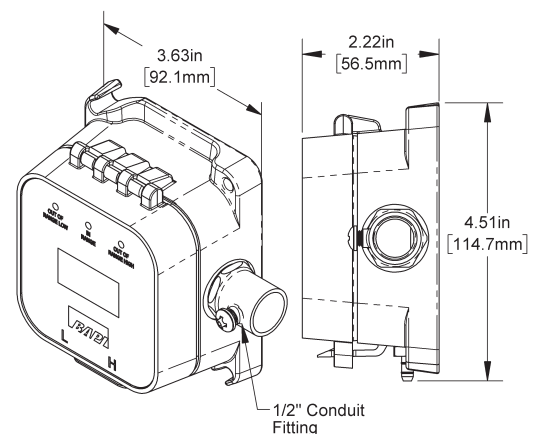

Specifications subject to change without notice.